

PCT

WORLD INTELLECTUAL PROPERTY ORGANIZATION
International Bureau



INTERNATIONAL APPLICATION PUBLISHED UNDER THE PATENT COOPERATION TREATY (PCT)

BEST AVAILABLE COPY

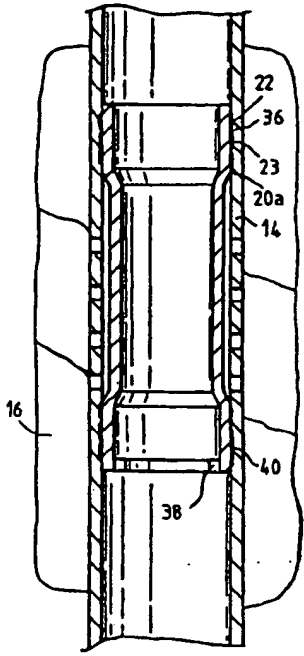
<p>(51) International Patent Classification ⁷ : E21B 29/10</p>	<p>A1</p>	<p>(11) International Publication Number: WO 00/37768 (43) International Publication Date: 29 June 2000 (29.06.00)</p>
<p>(21) International Application Number: PCT/GB99/04247 (22) International Filing Date: 22 December 1999 (22.12.99)</p> <p>(30) Priority Data: 9828234.6 22 December 1998 (22.12.98) GB 9900835.1 15 January 1999 (15.01.99) GB 9923783.6 8 October 1999 (08.10.99) GB 9924189.5 13 October 1999 (13.10.99) GB</p> <p>(71) Applicants: PETROLINE WELLSYSTEMS LIMITED (GB/GB); Offshore Technology Park, Claymore Drive, Bridge of Don, Aberdeen AB23 8GD (GB). ASTEC DEVELOPMENTS LIMITED (GB/GB); ODS Building, Greenbank Crescent, East Tullos, Aberdeen AB12 3BG (GB).</p> <p>(72) Inventors: METCALFE, Paul, David; North Wing, Bucklerburn Steading, Peterculter AB14 0NP (GB). SIMPSON, Neil, Andrew, Abercrombie; Burn of Daff Farm, Downies, Portlethen, Aberdeen AB12 4QX (GB).</p> <p>(74) Agents: MCCALLUM, William, Potter et al.; Cruikshank & Fairweather, 19 Royal Exchange Square, Glasgow G1 3AE (GB).</p>	<p>(81) Designated States: AU, BR, CA, NO, European patent (AT, BE, CH, CY, DE, DK, ES, FI, FR, GB, GR, IE, IT, LU, MC, NL, PT, SE).</p> <p>Published With international search report.</p>	
<p>(54) Title: METHOD AND APPARATUS FOR EXPANDING A LINER PATCH</p>		
<p>(57) Abstract</p> <p>A method of isolating a section of downhole tubing comprises: running a length of expandable tubing (20) into a tubing-lined borehole (12, 14) and positioning the expandable tubing (20) across a section of tubing to be isolated; deforming at least portions of the expandable tubing (36, 40) to increase the diameter of the portions to scalyingly engage the tubing (14) and to isolate the tubing section.</p> 		

FOR THE PURPOSES OF INFORMATION ONLY

Codes used to identify States party to the PCT on the front pages of pamphlets publishing international applications under the PCT.

AL	Albania	ES	Spain	LS	Lesotho	SI	Slovenia
AM	Armenia	FI	Finland	LT	Lithuania	SK	Slovakia
AT	Austria	FR	France	LU	Luxembourg	SN	Senegal
AU	Australia	GA	Gabon	LV	Latvia	SZ	Swaziland
AZ	Azerbaijan	GB	United Kingdom	MC	Monaco	TD	Chad
BA	Bosnia and Herzegovina	GE	Georgia	MD	Republic of Moldova	TG	Togo
BB	Barbados	GH	Ghana	MG	Madagascar	TJ	Tajikistan
BE	Belgium	GN	Guinea	MK	The former Yugoslav Republic of Macedonia	TM	Turkmenistan
BF	Burkina Faso	GR	Greece	ML	Mali	TR	Turkey
BG	Bulgaria	HU	Hungary	MN	Mongolia	TT	Trinidad and Tobago
BJ	Benin	IE	Ireland	MR	Mauritania	UA	Ukraine
BR	Brazil	IL	Israel	MW	Malawi	UG	Uganda
BY	Belarus	IS	Iceland	MX	Mexico	US	United States of America
CA	Canada	IT	Italy	NE	Niger	UZ	Uzbekistan
CF	Central African Republic	JP	Japan	NL	Netherlands	VN	Viet Nam
CG	Congo	KE	Kenya	NO	Norway	YU	Yugoslavia
CH	Switzerland	KG	Kyrgyzstan	NZ	New Zealand	ZW	Zimbabwe
CI	Côte d'Ivoire	KP	Democratic People's Republic of Korea	PL	Poland		
CM	Cameroon	KR	Republic of Korea	PT	Portugal		
CN	China	KZ	Kazakhstan	RO	Romania		
CU	Cuba	LC	Saint Lucia	RU	Russian Federation		
CZ	Czech Republic	LJ	Liechtenstein	SD	Sudan		
DE	Germany	LK	Sri Lanka	SE	Sweden		
DK	Denmark	LR	Liberia	SG	Singapore		
EE	Estonia						

METHOD AND APPARATUS FOR EXPANDING A LINER PATCH

This invention relates to a straddle, and in particular a straddle for use in selectively isolating a section of tubing. The invention also relates to a method of isolating a section of tubing.

5 In the oil and gas exploration and production industries, subsurface hydrocarbon-bearing formations are accessed via casing-lined wellbores. The lower section of a bore, which intersects the hydrocarbon-bearing formation, is typically lined with perforated "liner", oil and gas
10 flowing into the bore through the perforations. The location of the perforations is predetermined on the basis of surveys, to ensure that only selected formations are in fluid communication with the bore. Over the life of a well it may occur that the properties of particular formations
15 change, for example the pressure in a formation may fall, or a formation may begin to produce an unacceptably high volume of water. In these circumstances it is known to run straddles into the liner, these straddles being sections of tubing with sealing arrangements at either end. A straddle
20 may be located within the section of liner intersecting the problem formation, and the seals then set to isolate the section of liner between the seals. However, existing straddles are problematic to set, and the requirement to accommodate the seals and a seal setting mechanism result.

in a significant loss in bore cross section, which reduces the production capacity of the well and also makes it more difficult to access the section of well beyond the straddle.

5 It is among the objectives of embodiments of the present invention to provide an improved straddle which obviates or mitigates these difficulties.

According to the present invention there is provided a method of isolating a section of downhole tubing, the
10 method comprising:

running a length of expandable tubing into a tubing-lined borehole and positioning the expandable tubing across a section of tubing to be isolated; and

15 deforming the expandable tubing by increasing the diameter of at least portions thereof to sealingly engage the tubing and to isolate said section.

According to another aspect of the present invention there is provided apparatus for use in isolating a section of tubing-lined borehole, the apparatus comprising: a
20 length of expandable tubing; and an expander device including a radially extendable member for deforming at least portions of the expandable tubing to increase the diameter of said portions to sealingly engage a section of tubing to be isolated.

25 Preferably, the expandable tubing is deformed by compressive plastic deformation or yield of the tubing and a localised reduction in tubing wall thickness with a subsequent increase in tubing diameter. Conveniently this

is achieved by rolling expansion, that is the expander device is rotated within the expandable tubing with an expander member in rolling contact with an inner face of the expandable tubing.

5 The deformation of the expandable tubing preferably creates an annular extension. This annular extension may extend over all or a substantial portion of the expandable tubing, or may be restricted to a selected portions of the expandable tubing on either side of the section of tubing
10 to be isolated. The former arrangement will be more secure, but would be more difficult to remove from the tubing.

 The tubing lining the bore may be casing or liner, or may be secondary tubing, such as production tubing itself
15 positioned within a section of casing or liner.

 The expandable tubing may include relatively ductile portions corresponding to the portions of the tubing to be expanded. These portions may be welded or otherwise secured to portions of less ductile tubing.

20 The expandable tubing is preferably initially cylindrical.

 Preferably, the expander device comprises a body carrying a plurality of expander roller members. Most preferably, a plurality of the expander members are
25 radially extendable. Preferably, the expander members are fluid activated, for example the members may be operatively associated with a piston. In one embodiment, the members may be mounted on respective radially movable pistons and

in other embodiments the members may have tapered ends for engaging cones or wedges coupled to an axially movable piston.

5 The expandable tubing may carry seal bands on an outer surface thereof. The seal bands may comprise at least one of an elastomeric seal and a band of relatively ductile metal, such as copper or a tin/lead alloy.

10 The expandable tubing may carry grip bands on an outer surface thereof. The grip bands may comprise relatively hard elements, such as balls, chips or grains, held in a matrix, whereby the elements bite into the relatively soft material of the tubing and the expandable tubing on deformation of the expandable tubing. In other embodiments the relatively hard elements may be in a form other than
15 bands.

These and other aspects of the present invention will now be described, by way of example, with reference to the accompanying drawings, in which:

20 Figures 1 and 2 are schematic sectional views of a straddle setting operation in accordance with an embodiment of an aspect of the present invention; and

Figure 3 is a schematic sectional view of a straddle in accordance with another embodiment of the present invention.

25 Reference is first made to Figure 1 of the drawings, which illustrates a straddle 10 in accordance with an embodiment of the present invention located in a section of a drilled bore 12 lined with perforated steel liner 14.

The straddle 10 has been run into the bore 12 and will be utilised to isolate a section of the bore 12, in particular a particular formation 16 which is in fluid communication with the bore via perforations 18 in a section of the liner 14.

The straddle 10 comprises a section of expandable tubing 20 carrying seal bands 22 of relatively ductile metal at each end, and also grip bands 23 comprising small elements of relatively hard material in a relatively ductile matrix. The tubing 20 defines a solid wall and is of slightly smaller outside diameter than the liner 14. Initially, the tubing 20 is of substantially constant diameter along its length. The ends of the tubing 20a, 20b and formed of relatively ductile metal and are welded to a central tubing section 20c.

The straddle is run into the bore 12 on a tool string 26, and is mounted to the string 26 via an expander device 28 mounted to the lower end of the string 26. The expander device 28 comprises a body 30 carrying three radially movable rollers 32. The body 30 also contains an axially movable piston which is coupled to a loading cone which cooperates with the tapered ends of the rollers 32. Application of elevated fluid pressure, via the tool string 26, thus urges the rollers 32 radially outwardly. Shear pins 34 couple the straddle 10 to the expander body 30.

In use, the straddle is run into the bore 12 on the tool string 26 and positioned across the group of perforations 18 to be closed off from the bore. Pressure

is then applied to the expander 28 to activate the rollers 32; an initial application of elevated pressure causes the rollers 32 to extend radially, and deforms the tubing 20, towards a triangular form, such that the areas of tubing 20 adjacent the rollers 32 are pushed into contact with the inner surface of the liner 14. This initial contact is sufficient to prevent relative rotation between the straddle 10 and the liner 14, such that when the string 26 and the expander 28 are rotated from surface the straddle 10 is held relative to the liner 14 and the pins 34 shear. The expander 28 then rotates within the straddle 10 with the rollers 32 in rolling contact with the inner wall of the tubing 20. The rollers 32 are urged outwardly and progressively compress the tubing wall to create a localised reduction in wall thickness, and a corresponding increase in wall diameter. There is thus created a annular section of increased tubing diameter 36 at the tubing end section 20a, as shown in Figure 2, which provides an interference fit with the surrounding liner 14, the sealing bands 22 being deformed to form a fluid-tight seal between the expanded tubing 36 and the liner 14. The hard material in the grip bands 23 also assists in keying the tubing section 36 to the liner 14. There may be a degree of elastic and even plastic deformation of the liner 14, which will serve to provide a more secure location for the straddle 10.

Following creation of the annular extension 36, the pressure in the tool string 26 is reduced such that the

rollers 32 may retract. The expander 28 is then advanced towards the lower end of the straddle 10, and engages a stop 38 provided on the lower end of the tubing 20. The pressure in the tool string is then increased once more to actuate the rollers 32, and the expander 28 is rotated to create a second annular section of increased diameter 40.

The expander 28 may then be deactivated and retrieved from the bore, leaving the straddle 10 locked in place in the bore, and serving to isolate the formation 16 from the bore.

To remove the straddle 10, the locking and sealing sections 36, 40 are milled out, and the remaining section of tubing then removed.

In other embodiments, the increased diameter sections 36, 40 may be formed simultaneously, by provision of two expanders located one at either end of the straddle.

Reference is now made to Figure 3 of the drawings, which illustrates a permanent straddle 50 in accordance with another embodiment of the invention locked and sealed in a bore 52. The straddle 50 is located in a substantially similar manner to the straddle 10 described above, however the straddle tubing 54 has been deformed along its whole length, such that there is a much larger area of contact between the tubing 54 and the surrounding liner 56, and a smaller loss in cross-section in the liner 56 from the provision of the straddle 50.

Those of skill in the art will recognise that the above described embodiments of the present invention

provide straddles which are relatively simple in construction and installation and which avoid many of the problems associated with prior art straddles featuring slips and energisable elastomer seals.

5 Those of skill in the art will also recognise that the embodiments described herein are merely exemplary and that various modifications and improvements may be made thereto without departing from the scope of the present invention. For example, the above described embodiments are shown
10 isolating sections of formation from a bore lined with perforated liner. In other embodiments, the straddle may be utilised to repair damaged tubing, including risers, casing, liner or production tubing. The straddle may be run in on any suitable form of tool string, including
15 reeled supports such as coiled tubing, when the straddle will be provided in combination with a downhole motor for rotating the expander 28.

CLAIMS

1. A method of isolating a section of downhole tubing,
the method comprising:
 running a length of expandable tubing into a tubing-
5 lined borehole and positioning the expandable tubing across
 a section of tubing to be isolated; and
 deforming at least portions of the expandable tubing
 to increase the diameter of said portions to sealingly
 engage the tubing and to isolate said section.
- 10 2. The method of claim 1, wherein the expandable tubing
 is deformed at least in part by compressive plastic
 deformation creating a localised reduction in tubing wall
 thickness with a subsequent increase in tubing diameter.
- 15 3. The method of claim 2, wherein the deformation is
 achieved by rolling expansion, that is an expander device
 is rotated within the expandable tubing with an expander
 member in rolling contact with an inner face of the
 expandable tubing.
- 20 4. The method of any of the preceding claims, wherein the
 deformation of the expandable tubing creates an annular
 extension.
5. The method of claim 4, wherein the annular extension

extends over a substantial portion of the expandable tubing.

5 6. The method of claim 5, wherein the annular extension extends over selected portions of the expandable tubing on either side of the section of tubing to be isolated.

7. The method of any of the preceding claims, wherein the expandable tubing includes relatively ductile portions corresponding to the portions of the tubing to be expanded.

10 8. The method of any of the preceding claims, wherein the expandable tubing is initially cylindrical.

9. The method of any of the preceding claims, wherein the expandable tubing is deformed by means of an expander device comprising a body carrying a plurality of expander roller members.

15 10. The method of claim 9, wherein a plurality of the expander members are radially extendable and the expander device is rotated to deform the expandable tubing.

20 11. The method of any of the preceding claims, wherein seal bands are provided on an outer face of the expandable tubing and are compressed between the deformed portions of the expandable tubing and the surrounding tubing.

12. The method of any of the preceding claims, wherein grip bands comprising relatively hard elements are provided on an outer face of the expandable tubing and engage between the deformed portions of the expandable tubing and the surrounding tubing.

13. Apparatus for use in isolating a section of tubing-lined borehole, the apparatus comprising: a length of expandable tubing; and an expander device including a radially extendable expander member for deforming at least portions of the expandable tubing to increase the diameter of said portions to sealingly engage a section of tubing to be isolated.

14. The apparatus of claim 13, wherein the expander member is rotatably mounted and the expander device is adapted to be rotatable within the expandable tubing with the expander member in rolling contact with an inner face of the expandable tubing.

15. The apparatus of claims 13 or 14, wherein the expandable tubing includes relatively ductile portions corresponding to the portions of the tubing to be expanded.

16. The apparatus of claim 13, 14 or 15, wherein the expandable tubing is cylindrical.

17. The apparatus of any of claims 13 to 16, wherein the

expander device comprises a body carrying a plurality of expander members in the form of rollers.

18. The apparatus of any of claims 13 to 17, wherein a plurality of the expander members are radially extendable.

5 19. The apparatus of claim 18, wherein the expander members are fluid activated.

20. The apparatus of any of claims 13 to 19, wherein the expandable tubing carries seal bands on an outer surface thereof.

10 21. The apparatus of any of claims 13 to 20, wherein the expandable tubing carries grip bands on an outer surface thereof.

15 22. The apparatus of claim 21, wherein the grip bands comprise relatively hard elements held in a matrix, whereby the elements bite into the relatively soft material of the tubing and the expandable tubing on deformation of the expandable tubing.

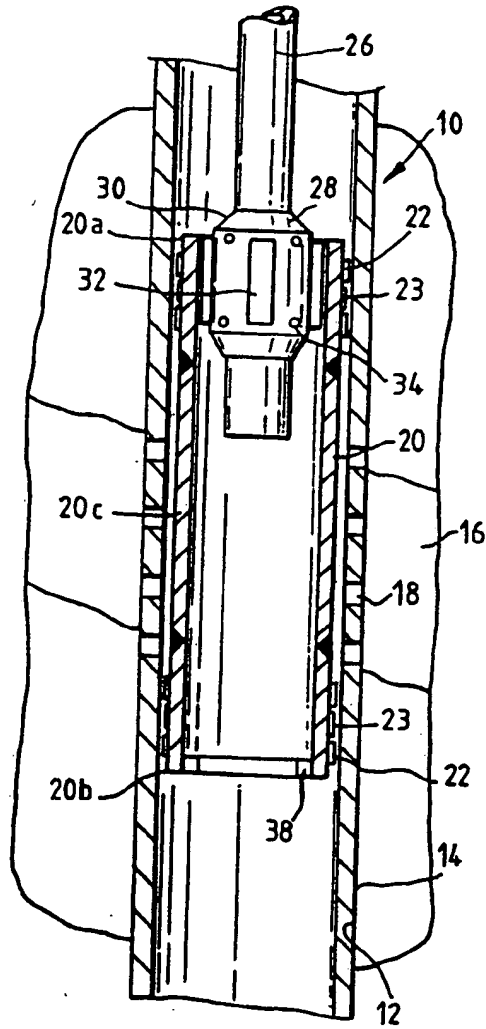

Fig. 1

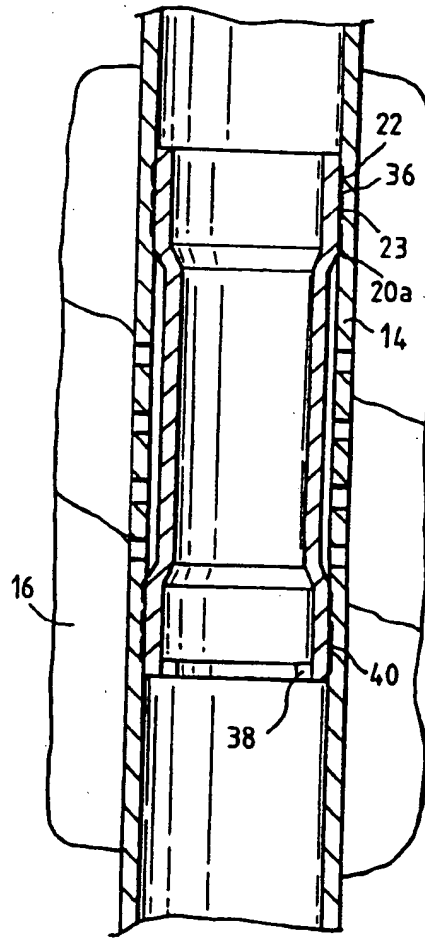

Fig. 2

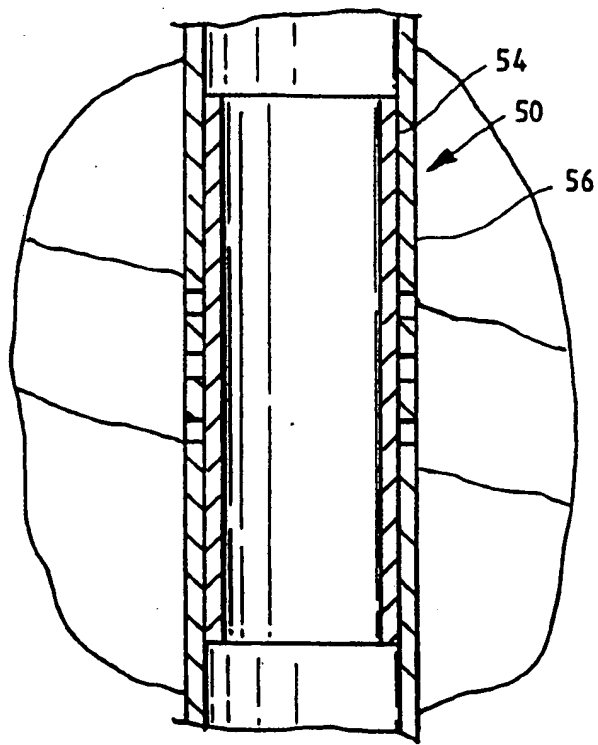

Fig. 3

INTERNATIONAL SEARCH REPORT

International Application No
PCT/GB 99/04247-

A. CLASSIFICATION OF SUBJECT MATTER
IPC 7 E21B29/10

According to International Patent Classification (IPC) or to both national classification and IPC

B. FIELDS SEARCHED

Minimum documentation searched (classification system followed by classification symbols)
IPC 7 E21B

Documentation searched other than minimum documentation to the extent that such documents are included, in the fields searched

Electronic data base consulted during the international search (name of data base and, where practical, search terms used)

C. DOCUMENTS CONSIDERED TO BE RELEVANT

Category*	Citation of document, with indication, where appropriate, of the relevant passages	Relevant to claim No.
X	US 5 014 779 A (MELING KONSTANTIN V ET AL) 14 May 1991 (1991-05-14) column 4, line 12-28; figure 2	1-5,8
Y	---	9,10
X	US 3 785 193 A (KINLEY M ET AL) 15 January 1974 (1974-01-15) abstract; figures 1-3	1,2,4,5,8
Y	---	13,14,16-18
Y	US 2 627 891 A (P.B. CLARK) 10 February 1953 (1953-02-10) figure 1	9,10,13,14,16-18
X	US 2 214 226 A (A. ENGLISH) 10 September 1940 (1940-09-10) figure 5	1,2,4-6,8

	-/-	

Further documents are listed in the continuation of box C.

Patent family members are listed in annex.

* Special categories of cited documents:

"A" document defining the general state of the art which is not considered to be of particular relevance

"E" earlier document but published on or after the international filing date

"L" document which may throw doubts on priority claim(s) or which is cited to establish the publication date of another citation or other special reason (as specified)

"O" document referring to an oral disclosure, use, exhibition or other means

"P" document published prior to the international filing date but later than the priority date claimed

"T" later document published after the international filing date or priority date and not in conflict with the application but cited to understand the principle or theory underlying the invention

"X" document of particular relevance; the claimed invention cannot be considered novel or cannot be considered to involve an inventive step when the document is taken alone

"Y" document of particular relevance; the claimed invention cannot be considered to involve an inventive step when the document is combined with one or more other such documents, such combination being obvious to a person skilled in the art.

"Z" document member of the same patent family

Date of the actual completion of the international search

24 February 2000

Date of mailing of the international search report

03/03/2000

Name and mailing address of the ISA

European Patent Office, P.B. 5018 Patentlaan 2
NL - 2280 HV Rijswijk
Tel. (+31-70) 340-2040, Tx. 31 651 epo nl,
Fax: (+31-70) 340-3018

Authorized officer

Schouten, A

INTERNATIONAL SEARCH REPORT

Int. Patent Application No.
PCT/GB 99/04247-

C.(Continuation) DOCUMENTS CONSIDERED TO BE RELEVANT

Category	Citation of document, with indication, where appropriate, of the relevant passages	Relevant to claim No.
X	US 3 191 677 A (M.M. KINLEY) 29 June 1965 (1965-06-29) claim 1; figure 7	1,2,4,5, 8
X	US 3 167 122 A (H.M. LANG) 26 January 1965 (1965-01-26) column 2, line 17-25; figures 2,3	1,2,4,5, 8

INTERNATIONAL SEARCH REPORT

Information on patent family members

Int. l. Application No
PCT/GB 99/04247

Patent document cited in search report	Publication date	Patent family member(s)	Publication date
US 5014779 A	14-05-1991	CA 1322151 A	14-09-1993
		WO 9005831 A	31-05-1990
		AU 621350 B	12-03-1992
		AU 3189889 A	12-06-1990
		DE 3887905 D	24-03-1994
		EP 0397875 A	22-11-1990
		NO 174637 B	28-02-1993
US 3785193 A	15-01-1974	NONE	
US 2627891 A	10-02-1953	NONE	
US 2214226 A	10-09-1940	NONE	
US 3191677 A	29-06-1965	NONE	
US 3167122 A	26-01-1965	NONE	